

BN-W / BNH-W Series Terminal Blocks

UL recognized, CSA certified, and TÜV compliant.
Touch-down terminals reduce wiring time.

- Molded from UL94V-0 material with excellent flame and shock resistance.
- Terminal blocks can be mounted on a 35-mm-wide DIN rail and 30-mm-wide IEC type C rail.



- 9.5-mm-wide marking strips can be used on all models. 17-mm-wide sliding type marking strips also available. (BN10W to BN30W)
- Terminal blocks of different shapes and capacities can be installed without using an end plate. (BN□10W to BN□150W)
- Screw and stud terminals available for large capacity terminal blocks.
- Additional mounting and removal of terminals is easy. (BN□10W to BN□150W)
- Complies with JIS C 2811.
- UL recognized, CSA certified, and EN compliant (TÜV approved). (Except common terminal)
- UL recognized for field wiring (FW2).

Applicable Standards	Mark	Certification Organization/ File No.
UL1059		UL recognized File No. E78117
CSA C 22.2 No.158		CSA File No. LR64803
EN60947-7-1		TÜV Rheinland License No. Standard: R9551701 Large Capacity: J9551516 J9650886 (BN500□, BN600□ only) Double-Deck: R9650688

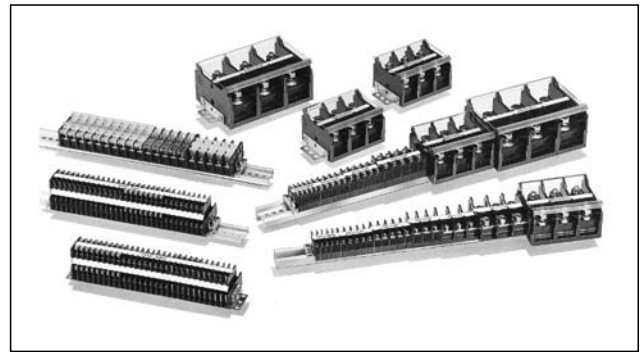

Touch-down terminal blocks reduce wiring time.
(BNH-W/BNDH-W Series)

1. Insert the Crimping Terminal
2. Push the Screw Down
3. Tighten the Screw

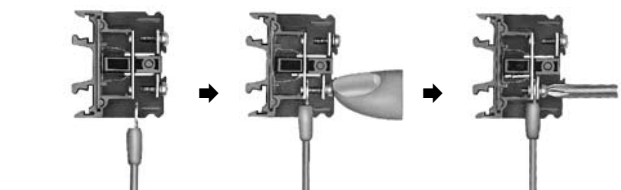

Terminal screw is always in the open position. No need to loosen the screw.
 Push the screw down to temporarily hold the wire in place.
 The screws can be tightened easily with a pneumatic screwdriver.

Material

Parts Name	Material
Housing	Modified PPE
Bus Bars	Brass (Nickel-plated)
Terminal Screw	Steel (Zinc chrome-plated)
Spring	Stainless steel (touch-down type only)

General Ratings

Dielectric Strength	2500V AC, 1 minute
Insulation Resistance	100 MΩ minimum
Operating Temperature	-25 to +55°C (no freezing)
Storage Temperature	-25 to +70°C (no freezing)
Operating Humidity	45 to 85% RH (no condensation)

Ratings/Terminal Screw Tightening Torque

Style	Part No.		UL/CSA Ratings		EN Ratings (*1)		JIS Ratings		Terminal Screw	Tightening Torque (N·m)
	Self-Lifting	Touch-Down	Voltage/ Current	Wire Size (AWG)	Voltage/ Current	Wire Size [mm ² /(AWG)]	Voltage/ Current	Wire Size (mm ²)		
Standard	BN10W *	BNH10W *	600V/15A	22-16	660V/16A	1.25/(22-16)	600V/16A	1.25	M3	0.6 to 1.0
	BN15MW *	BNH15MW *	600V/15A	22-14	660V/22A	2/(22-14)	600V/16A	1.25 (2) *2	M3	0.6 to 1.0
	BN15LW *	BNH15LW *	600V/20A	22-14	660V/22A	2/(22-14)	600V/21A	2	M3.5	1.0 to 1.3
	BN15MWT *	BNH15MWT *	600V/15A	22-14	660V/22A	2/(22-14)	600V/21A	2	M3.5	1.0 to 1.3
	BN15LWT *	BNH15LWT *	600V/30A	22-14	660V/22A	3.5/(22-14)	600V/30A	3.5	M4	1.4 to 2.0
	BN30W *	BNH30W *	600V/35A	18-10	660V/38A	5.5/(18-10)	600V/40A	5.5	M4	1.4 to 2.0
	BN40W *	BNH40W *	600V/40A	16-8	660V/50A	8/(16-8)	600V/50A	8	M5	2.6 to 3.7
	BN50W *	BNH50W *	600V/50A	16-6	660V/67A	14/(16-6)	600V/70A	14	M5	2.6 to 3.7
	BN75W *		600V/80A	16-4	660V/94A	22/(8-4)	600V/94A	22	M6	3.9 to 5.4
	BN100W *		600V/100A	16-2	660V/132A	38/(2)	600V/132A	38	M8	10 to 13.5
Large Capacity	BN150W *		600V/150A	16-1/0	660V/175A	60/(1/0)	600V/175A	60	M8	10 to 13.5
	BN150NW *		600V/150A	16-1/0	660V/175A	60/(1/0)	600V/175A	60	M8	10 to 13.5
	BN200BW□, BN200NW□		600V/200A	4/0	660V/240A	100/(4/0)	600V/240A	100	M10	21 to 28
	BN300BW□, BN300NW□		600V/310A	300MCM	660V/310A	150/(300MCM)	600V/310A	150	M10	21 to 28
	BN400BW□, BN400NW□		600V/350A	400MCM	660V/370A	200/(400MCM)	600V/370A	200	M12	38 to 49
	BN500BW□, BN500NW□		600V/500A	500MCM	660V/430A	240/(500MCM)	600V/430A	250	M16	83 to 116
	BN600NW□		600V/600A	600MCM	660V/520A	300/(600MCM)	600V/520A	325	M16	83 to 116
	With Disconnecting Switch	BNT20	—	—	—	—	—	600V/20A	5.5	M4
With Fuse	BNF10S	—	—	—	—	—	600V/10A	5.5	M4	1.4 to 2.0
	BNF10N	—	—	—	—	—	600V/10A	5.5	M4	1.4 to 2.0
Double-Deck	BND15W	BNDH15W	600V/10A	22-14	660V/22A	2/(22-14)	600V/16A	1.25 (2) *2	M3	0.6 to 1.0
	BND15LW	BNDH15LW	600V/15A	22-14	660V/22A	2/(22-14)	600V/21A	2	M3.5	1.0 to 1.3
	BND15WT	BNDH15WT	600V/15A	22-14	660V/22A	2/(22-14)	600V/21A	2	M3.5	1.0 to 1.3
Common Terminal	BN15MC□	—	—	—	—	—	600V/16A Common Current	1.25 (2) *2	M3	0.6 to 1.0

*1: Ratings approved by TÜV based on EN60947-7-1.

*2: The rated applicable wire size is 1.25 mm², but 2 mm² wires can also be connected. The wire size in () does not comply with JIS standards.

*3: Part No. with * is UL recognized for field wiring (FW2).

BN-W / BNH-W Series Terminal Blocks

Terminal Blocks

Terminal Style		Part No.	Ordering No.	Applicable Wire (mm ²)	Terminal Screw	Width (mm)	Package Quantity	Page	
Standard									
Self-Lifting	1-pole	16A	BN10W	BN10WPN50	1.25	M3	7	50	
			BN15MW	BN15MWPN50	1.25 (2) (Note)	M3	8	50	
		21A	BN15LW	BN15LWPN50	2	M3.5	10.5	50	12
			BN15MWT	BN15MWTPN50	2	M3.5	8	50	
		30A	BN15LWT	BN15LWTPN50	3.5	M4	10.5	50	13
		40A	BN30W	BN30WPN50	5.5	M4	12	50	
		50A	BN40W	BN40WPN20	8	M5	14	20	14
70A	BN50W	BN50WPN20	14	M5	15.5	20			
Touch-Down	1-pole	16A	BNH10W	BNH10WPN50	1.25	M3	7	50	
			BNH15MW	BNH15MWPN50	1.25 (2) (Note)	M3	8	50	
		21A	BNH15LW	BNH15LWPN50	2	M3.5	10.5	50	12
			BNH15MWT	BNH15MWTPN50	2	M3.5	8	50	
		30A	BNH15LWT	BNH15LWTPN50	3.5	M4	10.5	50	13
		40A	BNH30W	BNH30WPN50	5.5	M4	12	50	
		50A	BNH40W	BNH40WPN20	8	M5	14	20	14
70A	BNH50W	BNH50WPN20	14	M5	15.5	20			
Large Capacity (Rail Mount)									
Screw	1-pole	94A	BN75W	BN75WPN10	22	M6	20	10	
		132A	BN100W	BN100WPN05	38	M8	26	5	
		175A	BN150W	BN150WPN05	60	M8	26	5	
	2-pole	240A	BN200BW2	BN200BW2	100	M10	37	1	17
			BN200BW3	BN200BW3					
			BN200BW4	BN200BW4					
	3-pole	310A	BN300BW2	BN300BW2	150	M10	44	1	18
			BN300BW3	BN300BW3					
			BN300BW4	BN300BW4					
	4-pole	370A	BN400BW2	BN400BW2	200	M12	57	1	19
BN400BW3			BN400BW3						
BN400BW4			BN400BW4						
Stud	2-pole	240A	BN200NW2	BN200NW2	100	M10	37	1	17
			BN200NW3	BN200NW3					
			BN200NW4	BN200NW4					
	3-pole	310A	BN300NW2	BN300NW2	150	M10	44	1	18
			BN300NW3	BN300NW3					
			BN300NW4	BN300NW4					
	4-pole	370A	BN400NW2	BN400NW2	200	M12	57	1	19
BN400NW3			BN400NW3						
BN400NW4			BN400NW4						
Large Capacity (Surface Mount)									
Screw	2-pole	240A	BN200BW2K	BN200BW2K	100	M10	37	1	17
			BN200BW3K	BN200BW3K					
			BN200BW4K	BN200BW4K					
	3-pole	310A	BN300BW2K	BN300BW2K	150	M10	44	1	18
			BN300BW3K	BN300BW3K					
			BN300BW4K	BN300BW4K					
	4-pole	370A	BN400BW2K	BN400BW2K	200	M12	57	1	19
			BN400BW3K	BN400BW3K					
BN400BW4K			BN400BW4K						
Stud	2-pole	430A	BN500BW2K	BN500BW2K	250	M16	57	1	20
			BN500BW3K	BN500BW3K					
			BN500BW4K	BN500BW4K					
	3-pole	240A	BN200NW2K	BN200NW2K	100	M10	37	1	17
			BN200NW3K	BN200NW3K					
			BN200NW4K	BN200NW4K					
	4-pole	310A	BN300NW2K	BN300NW2K	150	M10	44	1	18
BN300NW3K			BN300NW3K						
BN300NW4K			BN300NW4K						
2-pole	370A	BN400NW2K	BN400NW2K	200	M12	57	1	19	
		BN400NW3K	BN400NW3K						
		BN400NW4K	BN400NW4K						
3-pole	430A	BN500NW2K	BN500NW2K	250	M16	57	1	20	
		BN500NW3K	BN500NW3K						
		BN500NW4K	BN500NW4K						
4-pole	520A	BN600NW2K	BN600NW2K	325	M16	57	1	20	
		BN600NW3K	BN600NW3K						
		BN600NW4K	BN600NW4K						

* The rated applicable wire size is 1.25 mm², but 2 mm² wires can also be connected.
The wire size in () does not comply with JIS standards.

BN-W / BNH-W Series Terminal Blocks

Terminal Blocks

Terminal Style			Part No.	Ordering No.	Applicable Wire (mm ²)	Terminal Screw	Width (mm)	Package Quantity	Page
With Disconnecting Switch, Fuse									
Disconnecting Switch	20A	1-pole	BNT20	BNT20PN20	5.5	M4	15	20	21
With Fuse	10A	1-pole	BNF10S-□ BNF10N-□	BNF10S-□APN20 BNF10N-□APN20	5.5	M4	15	20	
Double-Deck Terminal Block									
Self-Lifting	16A	1-pole	BND15W	BND15WPN25	1.25 (2)*	M3	8	25	22
Touch-Down			BNDH15W	BNDH15WPN25					
Self-Lifting	21A	1-pole	BND15LW	BND15LWPN25	2	M3.5	8	25	
Touch-Down			BNDH15LW	BNDH15LWPN25					
Self-Lifting	21A	1-pole	BND15WT	BND15WTPN25	2	M3.5	12	25	
Touch-Down			BNDH15WT	BNDH15WTPN25					
Common Terminal									
Self-Lifting Type 16A (Common Current)		4-pole	BN15MC4	BN15MC4PN10	1.25 (2)*	M3	8	10	23
		8-pole	BN15MC8	BN15MC8PN10					
		10-pole	BN15MC10	BN15MC10PN10					

* The wire size in () does not comply with JIS standards.
 The rated applicable wire size is 1.25 mm², but 2 mm² wires can also be connected.
 Specify the fuse rating in place of □. 1A: 1, 3A: 3, 5A: 5.



Accessories

When ordering accessories, check if the accessories are necessary by referring to the table.
 X: Necessary
 O: Optional

Terminal		Part No.	Accessories (X: Necessary)												
			End Plate	Rail	End Clip	Rail Mounting Clip	Dust Cover	Marking Strip	Marking Strip Fastener	Sliding Marking Strip	Jumper	Removal Tool	Surface Mount Clip	Connecting Rod	Connecting Nut
Standard	16A to 40A Self-Lifting Touch-Down	BN10W, BN15MW, BN15LW, BN15MWT, BN15LWT, BN30W	X	X	X	O	O	O	O	O	O	O	—	—	—
		BNH10W, BNH15MW, BNH15LW, BNH15MWT, BNH15LWT, BNH30W	X	X	X	O	O	O	O	—	O	O	—	—	—
	50A to 70A Self-Lifting Touch-Down	BN40W, BN50W, BNH40W, BNH50W	X	X	X	O	O	O	O	—	O	—	—	—	—
Large Capacity	Rail Mount 1-Pole 94A to 175A	BN75W, BN100W, BN150W, BN150NW	X	X	X	O	O	O	O	—	—	—	—	—	—
	Rail Mount 240A to 370A	BN200BW□, BN300BW□, BN400BW□ BN200NW□, BN300NW□, BN400NW□	—	X	X	—	Supplied	Supplied	—	—	—	—	—	—	—
	Surface Mount 240A to 520A	BN200BW□K, BN300BW□K, BN400BW□K BN200NW□K, BN300NW□K, BN400NW□K BN500BW□K, BN500NW□K, BN600NW□K	—	—	—	—	Supplied	Supplied	—	—	—	—	—	—	—
With Disconnecting Switch	BNT20	X	X	X	O	O	O	O	—	—	—	—	—	—	
With Fuse	BNF10S, BNF10N	X	X	X	O	—	O	O	—	—	—	—	—	—	
Double-Deck	BND15W, BND15LW, BNDH15W, BNDH15LW, BND15WT, BNDH15WT	X	X *1	X *1	O	O	O	O	—	X	—	X *2	X	X	
Common Terminal	BN15MC□	—	X	X	—	O	O	O	O	—	—	—	—	—	
			24	25			26			27	28				
Page															

*1: Accessory not necessary for surface mounting.
 *2: Accessory not necessary for rail mounting.
 Specify the number of poles in place of □.

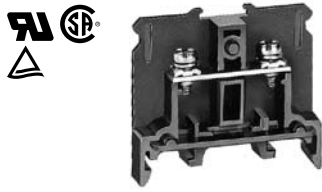
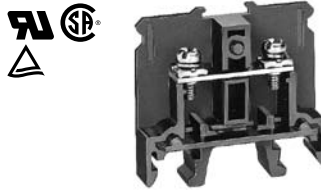
BN-W / BNH-W Series Terminal Blocks

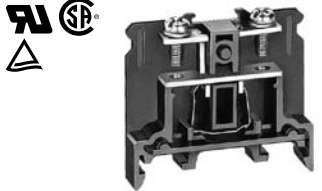
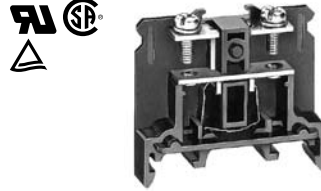
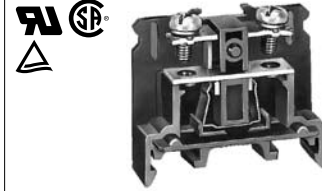
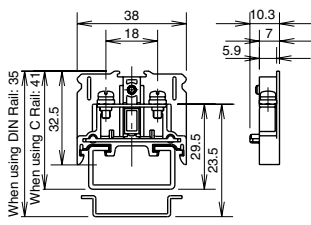
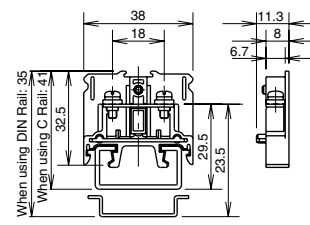
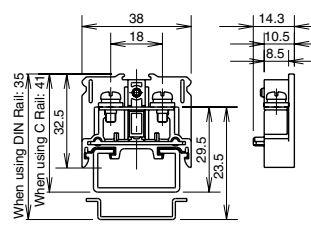
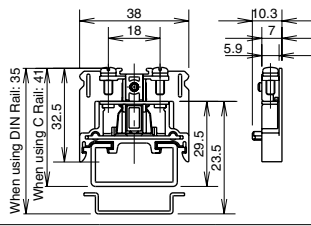
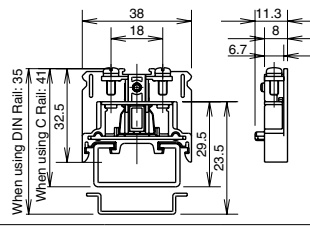
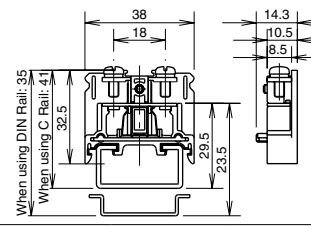
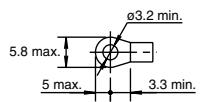
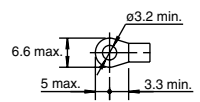
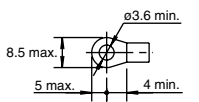
Standard	Self-Lifting Terminal			Touch-Down Terminal						
	Part No.	BN10W 16A M3	BN15MW 16A M3	BN15LW 21A M3.5	Part No.	BNH10W 16A M3	BNH15MW 16A M3	BNH15LW 21A M3.5		
Dimensions										
										
	Ordering No.	BN10WPN50	BN15MWPN50	BN15LWPN50	BNH10WPN50	BNH15MWPN50	BNH15LWPN50			
	Package Quantity	50	50	50	50	50	50			
Weight (Approx.)	6.5g	7.3g	10g	7.5g	8.2g	11.2g				
Standards	UL/CSA	EN	JIS	UL/CSA	EN	JIS	UL/CSA	EN	JIS	
	Insulation Voltage	600V	660V	600V	600V	660V	600V	660V	600V	
	Wire Size *1	22-16 AWG	1.25 mm ² (22-16 AWG)	1.25 mm ²	22-14 AWG	2 mm ² (22-14 AWG)	1.25 mm ² (2mm ² max)	22-14 AWG	2 mm ² (22-14 AWG)	2 mm ²
	Rated Current *2	15A	16A	16A	15A	22A	16A	20A	22A	21A
Specification / Ratings	Terminal screw	M3			M3			M3.5		
	Crimping Terminal	1.25-3			1.25-3 (2-3)			2-3.5		
	Max. No. of Crimping Terminals	2			2			2		
	Tightening Torque	0.6 to 1.0 N·m			0.6 to 1.0 N·m			1.0 to 1.3 N·m		
Crimping Terminal Dimensions (mm) *3										
	End Plate	BNE15W (see page 24)								
Dust Cover	BNC230 (see page 25)									
Marking Strip	PVC 1m/BNM7, Fiber glass 1m/BNM9, PVC 25m/BNM725 (see page 26)									
Marking Strip Fastner	BNM3 (see page 26)									
DIN Rail/End Clip	Aluminum: BAA1000, Steel: BAP1000 (see page 24)/BNL6 (see page 25)									
C Rail/End Clip	Aluminum: BNCA1000, Steel: BNCP1000 (see page 24)/BNL7 (see page 25)									
DIN + C Rail/End Clip	Aluminum: BNJA1000 (see page 24)/BNL6, BNL7 (see page 25)									

*1: The wire size in () does not comply with JIS standards.

*2: The rated current differs according to operating conditions. See "Selecting Terminal Blocks by Current According to JIS Standards" on page 5.

*3: Use a CSA certified crimping terminal when using the terminal block as a CSA certified product.

BN-W / BNH-W Series Terminal Blocks

BN15MWT 21A M3.5			BN15LWT 30A M4			BN30W 40A M4		
BN15MWTPN50			BN15LWTPN50			BN30WPN50		
50			50			50		
7g			10g			15.6g		
BNH15MWT 21A M3.5			BNH15LWT 30A M4			BNH30W 40A M4		
BNH15MWTPN50			BNH15LWTPN50			BNH30WPN50		
50			50			50		
8g			11g			16.8g		
UL/CSA	EN	JIS	UL/CSA	EN	JIS	UL/CSA	EN	JIS
600V	660V	600V	600V	660V	600V	600V	660V	600V
22-14 AWG	2 mm ² (22-14 AWG)	2 mm ²	22-14 AWG	3.5 mm ² (22-14 AWG)	3.5 mm ²	18-10 AWG	5.5 mm ² (18-10 AWG)	5.5 mm ²
15A	22A	21A	30A	22A	30A	35A	38A	40A
M3.5			M4			M4		
1.25-3.5 to 2-3.5			1.25-4 to 3.5-4			1.25-4 to 5.5-4		
2			2			2		
1.0 to 1.3 N·m			1.4 to 2.0 N·m			1.4 to 2.0 N·m		
BNE15W (see page 24)						BNE30W (see page 24)		
BNC230 (see page 25)						BNC230 (see page 25)		
PVC 1m/BNM7, Fiber glass 1m/BNM9, PVC 25m/725 (see page 26)								
BNM3 (see page 26)								
Aluminum: BAA1000, Steel: BAP1000 (see page 24) /BNL6 (see page 25)								
Aluminum: BNCA1000, Steel: BNCP1000 (see page 24)/BNL7 (see page 25)								
Aluminum: BNJA1000 (see page 24)/BNL6 (see page 25)						Aluminum: BNJA1000 (see page 24)/BNL6, BNL7 (see page 25)		

*1: The wire size in () does not comply with JIS standards.

*2: The rated current differs according to operating conditions. See "Selecting Terminal Blocks by Current According to JIS Standards" on page 5.

*3: Use a CSA certified crimping terminal when using the terminal block as a CSA certified product.

BN-W / BNH-W Series Terminal Blocks

		BN40W 50A M5			BN50W 70A M5				
Standard	Self-Lifting Terminal	Part No.	BN40W 50A M5			BN50W 70A M5			
		Dimensions							
		Ordering No.	BN40WPN20			BN50WPN20			
		Package Quantity	20			20			
	Weight (Approx.)	25g			25.4g				
	Touch-Down Terminal	Dimensions	Part No.	BNH40W 50A M5			BNH50W 70A M5		
			Dimensions						
			Ordering No.	BNH40WPN20			BNH50WPN20		
			Package Quantity	20			20		
		Weight (Approx.)	25g			29g			
Standards		UL/CSA	EN	JIS	UL/CSA	EN	JIS		
Specification / Ratings	Insulation Voltage	600V	660V	600V	600V	660V	600V		
	Wire Size *1	16-8 AWG	8 mm ² (16-8 AWG)	8 mm ²	16-6 AWG	14 mm ² (16-6 AWG)	14 mm ²		
	Rated Current *2	40A	50A	50A	50A	67A	70A		
	Terminal screw	M5			M5				
	Crimping Terminal	1.25-5 to 8-5			1.25-5 to 14-5				
	Max. No. of Crimping Terminals	2			2				
	Tightening Torque	2.6 to 3.7 N·m			2.6 to 3.7 N·m				
Crimping Terminal Dimensions (mm) *3									
Accessories	End Plate	BNE40W (see page 24)			BNE50W (see page 24)				
	Dust cover	BNC330 (see page 25)			BNC320 (see page 25)				
	Marking Strip	PVC 1m/BNM7, Fiber glass 1m/BNM9, PVC 25m/725 (see page 26)							
	Marking Strip Fastner	BNM3 (see page 26)							
	DIN Rail/End Clip	Aluminum: BAA1000, Steel: BAP1000 (see page 24)/ BNL6 (see page 25)			Aluminum: BAA1000, Steel: BAP1000 (see page 24)/ BNL8 (see page 25)				
	C Rail/End Clip	Aluminum: BNCA1000, Steel: BNCP1000 (see page 24)/ BNL7 (see page 25)			Aluminum: BNCA1000, Steel: BNCP1000 (see page 24)/ BNL8 (see page 25)				
	DIN + C Rail/End Clip	Aluminum: BNJA1000 (see page 24)/ BNL6, BNL7 (see page 25)			Aluminum: BNJA1000 (see page 24) /BNL8 (see page 25)				

*1: The wire size in () does not comply with JIS standards.

*2: The rated current differs according to operating conditions. See "Selecting Terminal Blocks by Current According to JIS Standards" on page 5.

*3: Use a CSA certified crimping terminal when using the terminal block as a CSA certified product.

BN-W / BNH-W Series Terminal Blocks

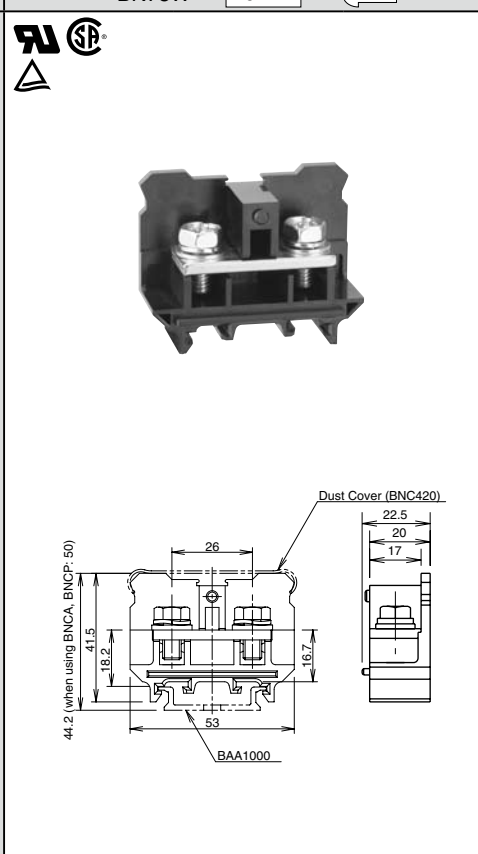
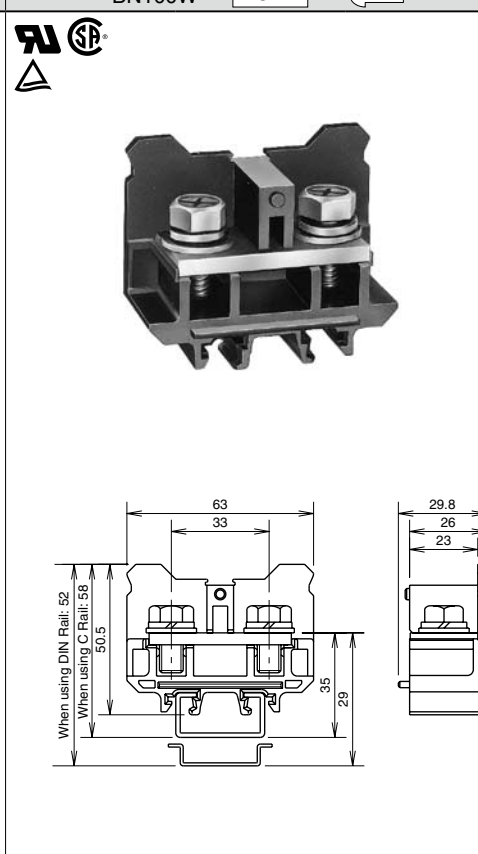
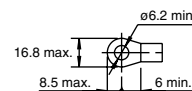
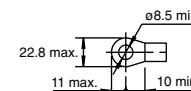
Part No.		BN75W	94A	M6	BN100W	132A	M8	
Large Capacity Screw Terminal	Dimensions							
	Ordering No.	BN75WPN10			BN100WPN05			
	Package Quantity	10			5			
	Weight (Approx.)	45g			86g			
Standards	UL/CSA	EN	JIS	UL/CSA	EN	JIS		
Insulation Voltage	600V	660V	600V	600V	660V	600V		
Wire Size	16-4 AWG	22 mm ² (8-4 AWG)	22 mm ²	16-2 AWG	38 mm ² (2AWG)	38 mm ²		
Rated Current *1	80A	94A	94A	100A	132A	132A		
Terminal screw *2	M6			M8				
Crimping Terminal	2-6 to 22-6			2-8 to 38-8				
Max. No. of Crimping Terminals	2			2				
Socket Wrench	12.7 mm square drive hexagonal socket 10			12.7 mm square drive hexagonal socket 13				
Tightening Torque	3.9 to 5.4 N·m			10 to 13.5 N·m				
Crimping Terminal Dimensions (mm) *3								
End Plate	BNE75W (see page 24)			BNE100W (see page 24)				
Dust Cover	BNC420 (see page 25)			BNC520 (see page 25)				
Marking Strip	PVC 1m/BNM7, Fiber glass 1m/BNM9, PVC 25m/BNM725 (see page 26)							
Marking Strip Fastener	BNM3 (see page 26)							
DIN Rail/End Clip	Aluminum: BAA1000, Steel: BAP1000 (see page 24)/BNL8 (see page 25)							
Type C Rail/End Clip	Aluminum: BNCA1000, Steel: BNCP1000 (see page 24)/BNL8 (see page 25)							
DIN+Type C Rail/End Clip	Aluminum: BNJA1000 (see page 24)/BNL8 (see page 25)							

*1: The rated current differs according to operating conditions. See "Selecting Terminal Blocks by Current According to JIS Standards" on page 5.

*2: The grooves on the head of the hex bolt are for temporary tightening. For proper tightening, use an applicable socket wrench and tighten within the range of the recommended tightening torque.

*3: Use a CSA certified crimping terminal when using the terminal block as a CSA certified product.

BN-W / BNH-W Series Terminal Blocks

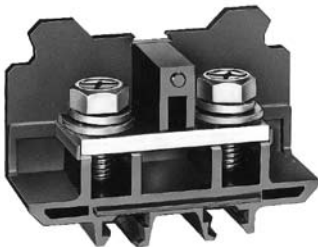
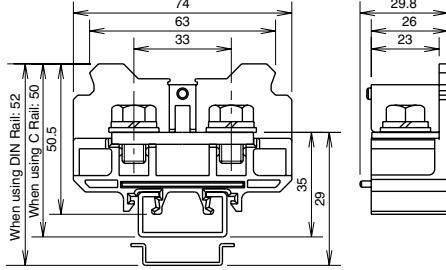
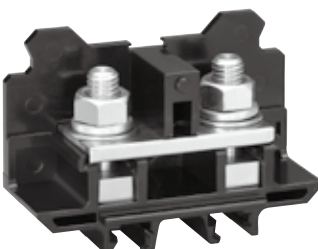
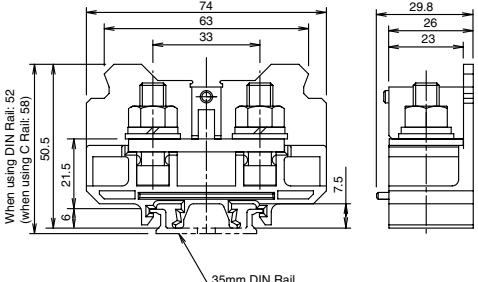
Large Capacity Screw Terminal	Part No.	BN150W	175A	M8	BN150NW	175A	M8	
	Dimensions	 				 		
Ordering No.	BN150WPN05				BN150NWP05			
Packaging Quantity	5				5			
Weight (Approx.)	88g				95g			

Standards	UL/CSA	EN	JIS	—	—	JIS
Insulation Voltage	600V	660V	660V	—	—	600V
Wire Size	16-1/0 AWG	60 mm ² (1/0 AWG)	60 mm ²	—	—	60 mm ²
Rated Current *1	150A	175A	175A	—	—	175A
Terminal screw *2	M8			M8		
Crimping Terminal	2-8 to 60-8			2-8 to 60-8		
Max. No. of Crimping Terminals	2			2		
Socket Wrench	12.7 mm square drive hexagonal socket 13 (*2)			12.7 mm square drive hexagonal socket 13 (*2)		
Tightening Torque	10 to 13.5 N·m			10 to 13.5 N·m		

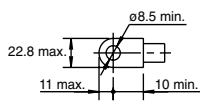
Crimping Terminal Dimensions (mm) *3	
End Plate	BNE150W (see page 24)
Dust Cover	BNC520 (see page 25)
Marking Strip	PVC 1m/BNM7, Fiber glass 1m/BNM9 PVC 25m/BNM725 (see page 26)
Marking Strip Fastner	BNM3 (see page 26)
DIN Rail/End Clip	Aluminum BAA1000, Steel: BAP1000 (see page 24)/ BNL8 (see page 25)
Type C Rail/End Clip	Aluminum: BNCA1000, Steel: BNCP1000 (see page 24)/ BNL8 (see page 25)
DIN+Type C Rail/End Clip	Aluminum: BNJA1000 (see page 24)/BNL8 (see page 25)

Accessories	End Plate	Dust Cover	Marking Strip	Marking Strip Fastner	DIN Rail/End Clip	Type C Rail/End Clip	DIN+Type C Rail/End Clip
	BNE150W (see page 24)	BNC520 (see page 25)	PVC 1m/BNM7, Fiber glass 1m/BNM9 PVC 25m/BNM725 (see page 26)	BNM3 (see page 26)	Aluminum BAA1000, Steel: BAP1000 (see page 24)/ BNL8 (see page 25)	Aluminum: BNCA1000, Steel: BNCP1000 (see page 24)/ BNL8 (see page 25)	Aluminum: BNJA1000 (see page 24)/BNL8 (see page 25)





- *1: The rated current differs according to operating conditions. See "Selecting Terminal Blocks by Current According to JIS Standards" on page 5.
- *2: The grooves on the head of the hex bolt are for temporary tightening. For proper tightening, use an applicable socket wrench and tighten within the range of the recommended tightening torque.
- *3: Use a CSA certified crimping terminal when using the terminal block as a CSA certified product.
- *4: Applicable wrench or screwdriver can be used for tightening screws.

BN-W / BNH-W Series Terminal Blocks

		BN200BW□ 240A M10			BN200BW□K 240A M10 Surface Mount			
Large Capacity	Screw Terminal	Dimensions						
		Package Quantity	1			1		
	Weight (Approx.)	2P: 430g, 3P: 650g, 4P: 870g			2P: 490g, 3P: 710g, 4P: 930g			
	Part No.	BN200NW□ 240A M10			BN200NW□K 240A M10 Surface Mount			
Large Capacity	Stud Terminal	Dimensions						
		Package Quantity	1			1		
	Weight (Approx.)	2P: 500g, 3P: 720g, 4P: 940g			2P: 560g, 3P: 780g, 4P: 1000g			
	Part No.	BN200NW□ 240A M10			BN200NW□K 240A M10 Surface Mount			
Specification / Ratings	Standards	UL/CSA	EN	JIS	UL/CSA	EN	JIS	
	Insulation Voltage	600V	660V	600V	600V	660V	600V	
	Wire Size	4/0 AWG	100 mm ² (4/0 AWG)	100 mm ²	4/0 AWG	100 mm ² (4/0 AWG)	100 mm ²	
	Rated Current *1	200A	240A	240A	200A	240A	240A	
	Terminal Screw *2	M10			M10			
	Crimping Terminal	5.5-10 to 100-10			5.5-10 to 100-10			
	Max. No. of Crimping Terminals	2			2			
	Socket Wrench	12.7 mm square drive hexagonal socket 17 (*2)			12.7 mm square drive hexagonal socket 17 (*2)			
Tightening Torque	21 to 28 N·m			21 to 28 N·m				
Crimping Terminal Dimensions (mm) *3								
Accessories (Supplied)	End Plate, Dust Cover (see page 24, 25), Marking Strip (see page 26) are supplied. (Note) Marking Strip Fastener (BNM3) is not necessary.							
Accessories	DIN Rail	Aluminum: BAA1000, Steel: BAP1000 (see page 24)			—			
	C Rail	Aluminum: BNCA1000, Steel: BNCP1000 (see page 24)			—			
	DIN+C Rail	Aluminum: BNJA1000 (see page 24)			—			
	End Clip	BNL8 (see page 25)			—			

*1: The rated current differs according to operating conditions. See "Selecting Terminal Blocks by Current According to JIS Standards" on page 5.
 *2: The grooves on the head of the hex bolt are for temporary tightening. For proper tightening, use an applicable socket wrench and tighten within the range of the recommended tightening torque.
 *3: Use a CSA certified crimping terminal when using the terminal block as a CSA certified product.
 Specify the number of poles in place of □. 2-pole: 2, 3-pole: 3, 4-pole: 4.

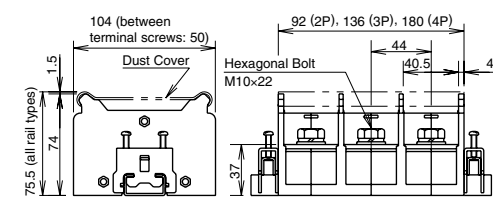
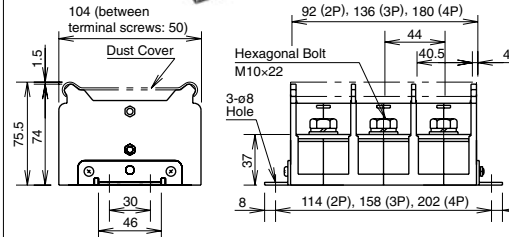
BN-W / BNH-W Series Terminal Blocks

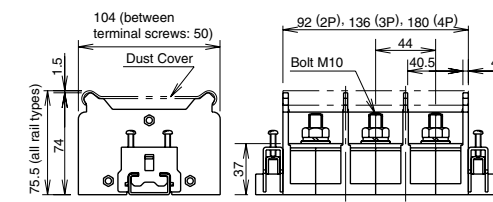
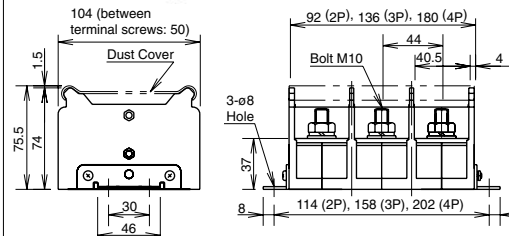
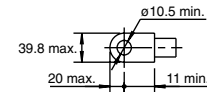
		BN300BW□ 310A M10			BN300BW□K 310A M10 Surface Mount		
		Large Capacity		Screw Terminal		 	
Dimensions				 			
Package Quantity	1			1			
Weight (Approx.)		2P: 480g, 3P: 750g, 4P: 1020g		2P: 540g, 3P: 810g, 4P: 1080g			
Large Capacity		Stud Terminal		 			
		Dimensions		 			
		Package Quantity	1		1		
Weight (Approx.)		2P: 540g, 3P: 810g, 4P: 1080g		2P: 600g, 3P: 870g, 4P: 1140g			
Standards		UL/CSA	EN	JIS	UL/CSA	EN	JIS
Specification / Ratings	Insulation Voltage	600V	660V	600V	600V	660V	600V
	Wire Size	300 MCM	150 mm ² (300 MCM)	150 mm ²	300 MCM	150 mm ² (300 MCM)	150 mm ²
	Rated Current *1	310A	310A	310A	310A	310A	310A
	Terminal Screw *2	M10			M10		
	Crimping Terminal	5.5-10 to 150-10			5.5-10 to 150-10		
	Max. No. of Crimping Terminals	2			2		
	Socket Wrench	12.7 mm square drive hexagonal socket 17 (*2)			12.7 mm square drive hexagonal socket 17 (*2)		
Tightening Torque	21 to 28 N·m			21 to 28 N·m			
Crimping Terminal Dimensions (mm) *3							
Accessories (Supplied)	End Plate, Dust Cover (see page 24, 25), Marking Strip (see page 26) are supplied. (Note) Marking Strip Fastener (BNM3) is not necessary.						
Accessories	DIN Rail	Aluminum: BAA1000, Steel: BAP1000 (see page 24)			—		
	C Rail	Aluminum: BNCA1000, Steel: BNCP1000 (see page 24)			—		
	DIN-C Rail	Aluminum: BNJA1000 (see page 24)			—		
	End Clip	BNL8 (see page 25)			—		

*1: The rated current differs according to operating conditions. See "Selecting Terminal Blocks by Current According to JIS Standards" on page 5.
 *2: The grooves on the head of the hex bolt are for temporary tightening. For proper tightening, use an applicable socket wrench and tighten within the range of the recommended tightening torque.
 *3: Use a CSA certified crimping terminal when using the terminal block as a CSA certified product.
 Specify the number of poles in place of □. 2-pole: 2, 3-pole: 3, 4-pole: 4.

BN-W / BNH-W Series Terminal Blocks

Large Capacity	Screw Terminal	Part no.	BN400BW□	370A	M12	BN400BW□K	370A	M12	Surface Mount
		Dimensions							
	Package Quantity	1			1				
	Weight (Approx.)	2P: 950g, 3P: 1400g, 4P: 1860g			2P: 1030g, 3P: 1480g, 4P: 1940g				
Large Capacity	Stud Terminal	Part No.	BN400NW□	370A	M12	BN400NW□K	370A	M12	Surface Mount
		Dimensions							
	Package Quantity	1			1				
	Weight (Approx.)	2P: 980g, 3P: 1460g, 4P: 1930g			2P: 1060g, 3P: 1540g, 4P: 1990g				

Standards	UL/CSA	EN	JIS	UL/CSA	EN	JIS	
Specification / Ratings	Insulation Voltage	600V	660V	600V	600V	660V	
	Wire Size	400 MCM	200 mm ² (400 MCM)	200 mm ²	400 MCM	200 mm ² (400 MCM)	
	Rated Current *1	350A	370A	370A	350A	370A	
	Terminal Screw	M12			M12		
	Crimping Terminal	14-12 to 200-12			14-12 to 200-12		
	Max. No. of Crimping Terminals	2			2		
	Socket Wrench	12.7 mm square drive hexagonal socket 19 (*2)			12.7 mm square drive hexagonal socket 19 (*2)		
Tightening Torque	38 to 49 N·m			38 to 49 N·m			
Crimping Terminal Dimensions (mm) *3							
Accessories (Supplied)	End Plate, Dust Cover (see page 24, 25), Marking Strip (see page 26) are supplied. (Note) Marking Strip Fastener (BNM3) is not necessary.						
Accessories	DIN Rail	Aluminum: BAA1000, Steel: BAP1000 (see page 24)			—		
	C Rail	Aluminum: BNCA1000, Steel: BNCP1000 (see page 24)			—		
	DIN+C Rail	Aluminum: BNJA1000 (see page 24)			—		
	End Clip	BNL8 (see page 25)			—		

*1: The rated current differs according to operating conditions. See "Selecting Terminal Blocks by Current According to JIS Standards" on page 5.
 *2: The grooves on the head of the hex bolt are for temporary tightening. For proper tightening, use an applicable socket wrench and tighten within the range of the recommended tightening torque.
 *3: Use a CSA certified crimping terminal when using the terminal block as a CSA certified product.
 Specify the number of poles in place of □. 2-pole: 2, 3-pole: 3, 4-pole: 4.

BN-W / BNH-W Series Terminal Blocks

		Part No	BN500BW□K	430A	M16	Surface Mount	—			
Large Capacity Surface Mount	Screw Terminal	Dimensions								
		Package Quantity	1							
	Weight (Approx.)	2P: 1550g, 3P: 2250g, 4P: 2950g								
	Stud Terminal	Dimensions								
Large Capacity Surface Mount	Screw Terminal	Dimensions								
		Package Quantity	1							
	Weight (Approx.)	2P: 1650g, 3P: 2400g, 4P: 3150g								
	Stud Terminal	Dimensions								
Standards	UL/CSA	EN	JIS	UL/CSA	EN	JIS				
Specification / Ratings	Insulation Voltage	600V	660V	600V	600V	660V	600V			
	Wire Size	500 MCM	240 mm ² (500 MCM)	250 mm ²	600 MCM	300 mm ² (600 MCM)	325 mm ²			
	Rated Current *1	500A	430A	430A	600A	520A	520A			
	Terminal Screw *2	M16								
	Crimping Terminal	14-16 to 200-16		325-16		14-16 to 200-16		325-16		
	Max. No. of Crimping Terminals	2		1		2		1		
	Socket Wrench	12.7 mm square drive hexagonal socket 24 (*2)						12.7 mm square drive hexagonal socket 24 (*2)		
Tightening Torque	83 to 116 N·m						83 to 116 N·m			
Crimping Terminal Dimensions (mm) *3										
Accessories (Supplied)	End Plate, Dust Cover (see page 24, 25), Marking Strip (see page 26) are supplied. (Note) Marking Strip Fastener (BNM3) is not necessary.									

*1: The rated current differs according to operating conditions. See "Selecting Terminal Blocks by Current According to JIS Standards" on page 5.
 *2: The grooves on the head of the hex bolt are for temporary tightening. For proper tightening, use an applicable socket wrench and tighten within the range of the recommended tightening torque.
 *3: Use a CSA certified crimping terminal when using the terminal block as a CSA certified product. Specify the number of poles in place of □. 2-pole: 2, 3-pole: 3, 4-pole: 4.

BN-W / BNH-W Series Terminal Blocks

		BNF10S 10A M4	BNF10N (With Lamp) 10A M4			BNT20 20A M4
Self-Lifting Terminal with Fuse				Self-Lifting Terminal with Disconnecting Switch		
		<p>Fuse Ratings</p> <ul style="list-style-type: none"> Rated Voltage: 250V Rated Current: 1, 3, 5A Cartridge Fuse: JIS C 6575-2 6.35×31.8 mm or 6.40×30.0 mm <p>Part No.: BNF10S-1A BNF10S-3A BNF10S-5A</p> <p>Cartridge used: FGB1 by FUJI Terminal Industry Co., Ltd.</p> <p>Notes: UL/CSA approved products shown below are not supplied with fuses. When UL/CSA approval is required for fuse terminal blocks, use UL/CSA-rated fuses.</p> <ul style="list-style-type: none"> Part No.: BNF10SW Rated Insulation Voltage: 600V Rated Current: 10A Applicable Wire: 18-10 AWG UL File No.: E78117 CSA File No.: LR64803 	<p>Internal Connection</p> <p>Notes: Neon lamp turns on when the fuse blows. For the neon lamp to turn on, the voltages must be from 100 to 250V AC.</p> <p>Fuse Ratings</p> <ul style="list-style-type: none"> Rated Voltage: 250V Rated Current: 1, 3, 5A Cartridge Fuse: JIS C 6575-2 6.35×31.8mm or 6.40×30.0mm <p>Part No.: BNF10N-1A BNF10N-3A BNF10N-5A</p>			<p>Notes:</p> <ul style="list-style-type: none"> Rated Current: 20A This terminal block cannot be used as a disconnect switch. When switching on/off, make sure that voltage is not applied.
Ordering No.		BNF10S-□APN20	BNF10N-□APN20	Ordering No.		BNT20PN20
Package Quantity		20	20	Package Quantity		20
Weight (Approx.)		34g	34g	Weight (Approx.)		36g
Standards		JIS	JIS			JIS
Specification / Ratings	Insulation Voltage	600V	600V			600V
	Wire Size	5.5 mm ²	5.5 mm ²			5.5 mm ²
	Rated Current	10A max.	10A max.			20A
	Terminal Screw	M4	M4			M4
	Crimping Terminal	1.25-4 to 5.5-4	1.25-4 to 5.5-4			1.25-4 to 5.5-4
	Max. No. of Crimping Terminals	2	2			2
	Tightening Torque	1.4 to 2.0 N·m	1.4 to 2.0 N·m			1.4 to 2.0 N·m
Crimping Terminal Dimensions (mm)						
Accessories	End Plate	BNE20 (see page 24)				
	Dust Cover	—				
	Marking Strip	—				
	DIN Rail/End Clip	Aluminum: BAA1000, Steel: BAP1000 (see page 24) /BNL6 (see page 25)				
	C Rail/End Clip	Aluminum: BNCA1000, Steel: BNCP1000 (see page 24) /BNL6 (see page 25)				
DIN+C Rail/End Clip	Aluminum: BNJA1000 (see page 24) /BNL6 (see page 25)					

BN-W / BNH-W Series Terminal Blocks



		Self-Lifting Terminal			Touch-Down Terminal					
		Part No.	BND15W 16A M3	BND15LW 21A M3.5	BND15WT 21A M3.5	Part No.	BNDH15W 16A M3	BNDH15LW 21A M3.5	BNDH15WT 21A M3.5	
Double-Deck Terminal Block	Dimensions									
		Ordering No.	BND15WPN25	BND15LWPN25	BND15WTPN25	BNDH15WPN25	BNDH15LWPN25	BNDH15WTPN25		
		Package Quantity	25	25	25	25	25	25		
	Weight (Approx.)	16g	23g	17g	17g	26g	17g			
Standards		UL/CSA	EN	JIS	UL/CSA	EN	JIS	UL/CSA	EN	JIS
Specification / Ratings	Insulation Voltage	600V	660V	600V	600V	660V	600V	600V	660V	600V
	Wire Size	22-14 AWG	2 mm ² (22-14 AWG)	1.25 mm ² (2 mm ² max)	22-14 AWG	2 mm ² (22-14 AWG)	2 mm ²	22-14 AWG	2 mm ² (22-14 AWG)	2 mm ²
	Rated Current *1	10A	22A	16A	15A	22A	21A	15A	22A	21A
	Terminal Screw *2	M3			M3.5			M3		
	Crimping Terminal	1.25-3 (2-3)			2-3.5			1.25-3.5 to 2-3.5		
	Max. No. of Crimping Terminals	2			2			2		
	Tightening Torque	0.6 to 1 N·m			1 to 1.3 N·m			1.0 to 1.3 N·m		
	Crimping Terminal (mm) *3									
Accessories	End Plate	BNDE15W/BNDE15W2 (see page 24)			BNDE15LW/BNDE15LW2 (see page 24)			BNDE15W/BNDE15W2 (see page 24)		
	Dust Cover	Upper Deck: BNC230, Lower Deck: BNC240 (see page 25)								
	Marking Strip	PVC 1m/BNM7, Fiber glass 1m/BNM9, PVC 25m/BNM725 (see page 26)								
	Marking Strip Fastener	BNM3 (see page 26)								
	Surface Mounting Clip	BNL2 (see page 28)								
	Connecting Rod/Connecting Nut	Connecting Rod: BNR1, BNR2, Connecting Nut: BNN1 (see page 28)								
	DIN Rail/End Clip	Aluminum: BAA1000, Steel: BAP1000 (see page 24)/BNL6 (see page 25)								
	C Rail/End Clip	Aluminum: BNCA1000, Steel: BNCP1000 (see page 24)/BNL7 (see page 25)								
DIN-C Rail/End Clip	Aluminum: BNJA1000 (see page 24)/BNL6, BNL7 (see page 25)									

*1: The rated current differs according to operating conditions. See "Selecting Terminal Blocks by Current According to JIS Standards" on page 5.

*2: The grooves on the head of the hex bolt are for temporary tightening. For proper tightening, use an applicable socket wrench and tighten within the range of the recommended tightening torque.

*3: Use a CSA certified crimping terminal when using the terminal block as a CSA certified product.

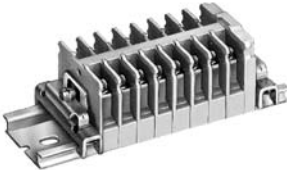
BN-W / BNH-W Series Terminal Blocks

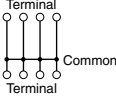
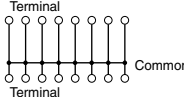
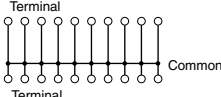
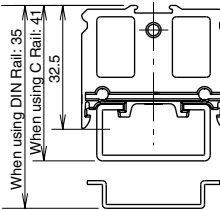
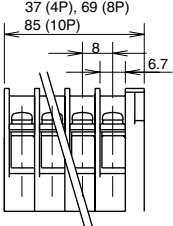
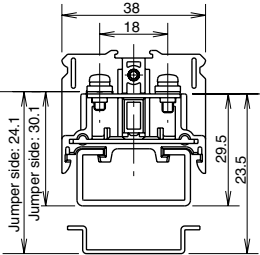
Common Terminal Self-Lifting Terminal	Part No.	BN15MC4	16A (common current)	M3	BN15MC8	16A (common current)	M3	BN15MC10	16A (common current)	M3
	No. of Poles	4			8			10		
	Shape									
										
	Dimensions									
	Ordering No.	BN15MC4PN10			BN15MC8PN10			BN15MC10PN10		
Package Quantity	10			10			10			
Weight (Approx.)	30g			57g			70g			
Color	Light Gray			Light Gray			Light Gray			

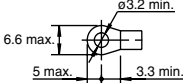
Standards	JIS														
Insulation Voltage	600V														
Wire Size	1.25 mm ² (2 mm ² max.)														
Rated Current	16A/Common Current														
Terminal Screw	M3														
Crimping Terminal	1.25-3 (2-3)														
Max. No. of Crimping Terminals	2														
Tightening Torque	0.6-1.0 N·m														
Crimping Terminal Dimensions (mm)															
Accessories	<table border="1"> <tbody> <tr> <td>End Plate</td> <td>Supplied</td> </tr> <tr> <td>Dust Cover</td> <td>BNC230 (see page 25)</td> </tr> <tr> <td>Marking Strip</td> <td>PVC 1m/BNM7, Fiber glass 1m/BNM9, PVC 25m/BNM725 (see page 26)</td> </tr> <tr> <td>Marking Strip Fastener</td> <td>BNM3 (see page 26)</td> </tr> <tr> <td>DIN Rail / End Clip</td> <td>Aluminum: BAA1000, Steel: BAP1000 (see page 24)/BNL6 (see page 25)</td> </tr> <tr> <td>C Rail / End Clip</td> <td>Aluminum: BNCA1000, Steel: BNCP1000 (see page 24)/BNL7 (see page 25)</td> </tr> <tr> <td>DIN+C Rail / End Clip</td> <td>Aluminum: BNJA1000 (see page 24)/BNL6, BNL7 (see page 25)</td> </tr> </tbody> </table>	End Plate	Supplied	Dust Cover	BNC230 (see page 25)	Marking Strip	PVC 1m/BNM7, Fiber glass 1m/BNM9, PVC 25m/BNM725 (see page 26)	Marking Strip Fastener	BNM3 (see page 26)	DIN Rail / End Clip	Aluminum: BAA1000, Steel: BAP1000 (see page 24)/BNL6 (see page 25)	C Rail / End Clip	Aluminum: BNCA1000, Steel: BNCP1000 (see page 24)/BNL7 (see page 25)	DIN+C Rail / End Clip	Aluminum: BNJA1000 (see page 24)/BNL6, BNL7 (see page 25)
End Plate	Supplied														
Dust Cover	BNC230 (see page 25)														
Marking Strip	PVC 1m/BNM7, Fiber glass 1m/BNM9, PVC 25m/BNM725 (see page 26)														
Marking Strip Fastener	BNM3 (see page 26)														
DIN Rail / End Clip	Aluminum: BAA1000, Steel: BAP1000 (see page 24)/BNL6 (see page 25)														
C Rail / End Clip	Aluminum: BNCA1000, Steel: BNCP1000 (see page 24)/BNL7 (see page 25)														
DIN+C Rail / End Clip	Aluminum: BNJA1000 (see page 24)/BNL6, BNL7 (see page 25)														

Note1: The rated applicable wire size is 1.25 mm², but 2 mm² wires can also be connected.
The wire size in () does not comply with JIS standards.

Note2: Do not remove the built-in common jumper. Common terminal type terminal blocks cannot be disassembled.

Note3: Make sure that all terminal screws are tightened to an appropriate tightening torque before power is applied.

Note4: Specifications are in compliance with JIS C 2811 except values in ().

Application Example

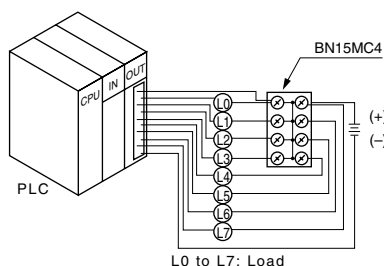

Features

- All terminals are short-circuited by a built-in common jumper. External jumpers are not required.
- Accessories (marking strip, cover, and rails) are compatible with standard types.
- Common terminal type terminal blocks can be combined with other standard types as they are identical in shape and in size as BN15MW.
- Color: Light Gray

BN-W / BNH-W Series Terminal Blocks

Accessories (End Plate / Rail)

End Plates

Used for ends of terminal blocks. Also used to hold the marking strips in place.

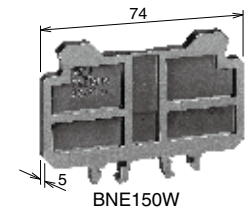
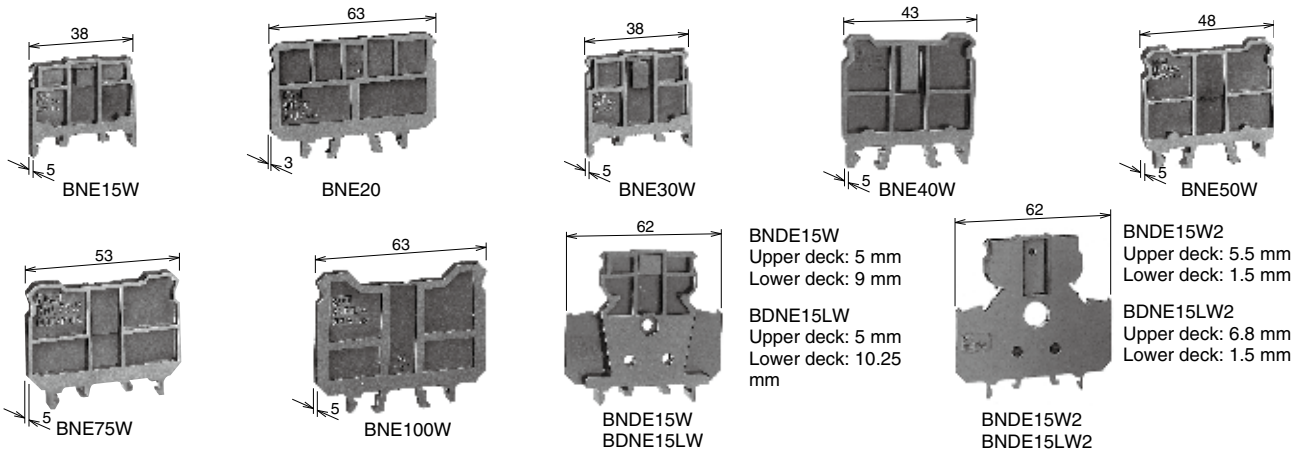

Securing a marking strip with the end plate

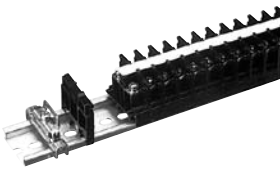

	Part No.	Ordering No.	Applicable Terminal Blocks	Thickness (mm)	Weight (Approx.)	Package Quantity
End Plate	BNE15W	BNE15WPN10	BN10W, BNH10W BN15MW, BNH15MW BN15LW, BNH15LW BN15MWT, BNH15MWT BN15LWT, BNH15LWT	5.0	4g	10
	BNE20	BNE20PN10	BNT20, BNF10S, BNF10N	3.0	8g	
	BNE30W	BNE30WPN10	BN30W, BNH30W	5.0	4g	
	BNE40W	BNE40WPN10	BN40W, BNH40W	5.0	5g	
	BNE50W	BNE50WPN10	BN50W, BNH50W	5.0	6g	
	BNE75W	BNE75WPN10	BN75W	5.0	6g	
	BNE100W	BNE100WPN10	BN100W	5.0	9g	
	BNE150W	BNE150WPN10	BN150W, BN150NW	5.0	10g	
	BNDE15W	BNDE15WPN10	BND15W, BND15WT, BNDH15W, BNDH15WT	Upper deck: 5.0 Lower deck: 9.0	5.5g	
	BNDE15LW	BNDE15LWPN10	BND15LW, BNDH15LW	Upper deck: 5.0 Lower deck: 10.25	6g	
End Plate for Securing End Plate	BNDE15W2	BNDE15W2PN10	BND15W, BND15WT, BNDH15W, BNDH15WT	Upper deck: 5.5 Lower deck: 1.5	5.5g	
	BNDE15LW2	BNDE15LW2PN10	BND15LW, BNDH15LW	Upper deck: 6.8 Lower deck: 1.5	6g	

Note: BNDE15W2 and BNDE15LW2 are end plates used for securing marking strips at the end of double deck terminal blocks.

Rails

Rails for mounting terminal blocks. Available in five styles.

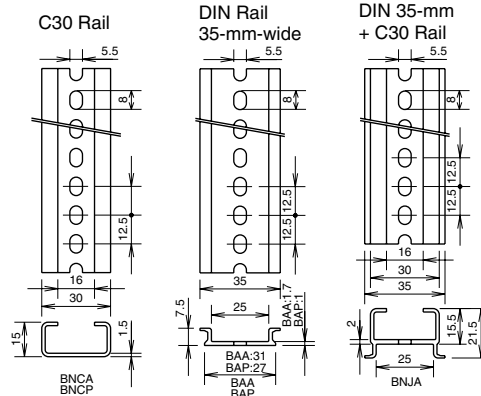
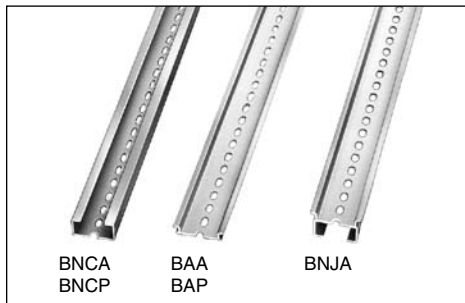

Approvals:
IEC60715
JIS C 2812

Length	Part No.	Ordering No.	Material	Weight (Approx.)	Package Quantity
1000 mm	BNCA1000	BNCA1000PN10	Aluminum	260g	10
	BNCP1000	BNCP1000PN10	Steel	700g	10
	BAA1000	BAA1000PN10	Aluminum	200g	10
	BAP1000	BAP1000PN10	Steel	320g	10
	BNJA1000	BNJA1000PN10	Aluminum	340g	10

BN-W / BNH-W Series Terminal Blocks

Accessories (End Clip / Rail Mounting Clip / Dust Cover)

End Clips

Used to secure the ends of the terminal blocks assembled on the rail.

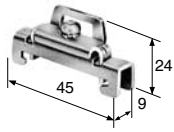

BNL6 (M4 Screw)
Tightening torque: 1.1 N·m

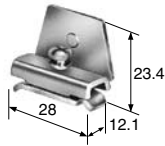

BNL7 (M4 Screw)

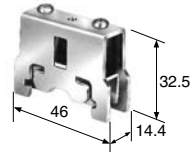

BNL8 (M4 Screw)

- Material: Steel
- Plating: Trivalent zinc chromate

Note: Slide the end clip onto the DIN rail.

Part No.	Ordering No.	Rails	For Terminal Blocks up to BND and BN□40	For BN□50 and BN□75	For Terminal Blocks BN□100 and larger	Weight (Approx.)	Package Quantity
BNL6	BNL6PN10	BAA, BAP	×	× (*2)	—	15.2g	10
BNL7	BNL7PN10	BNCA, BNCP, BNJA	×	× (*2)	—	16g	10
BNL8	BNL8PN10	BAA, BAP, BNCA, BNCP, BNJA	— (*1)	×	×	56g	10

- *1: Do not use BNL8 because the insulation distance will be insufficient if used.
*2: We recommend you to use BNL8 for secure hold.

Rail Mounting Clips

Used to raise the DIN rail from the panel surface.

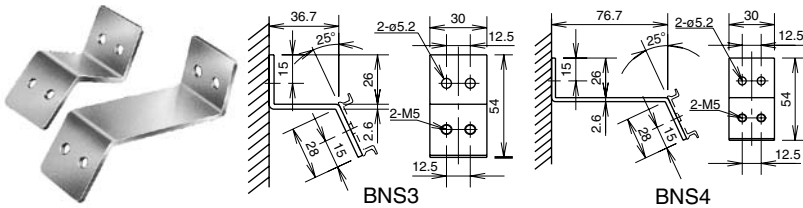

Part No.	Ordering No.	Weight (Approx.)	Package Quantity
BNS3	BNS3PN10	51.3g	10
BNS4	BNS4PN10	76.2g	10

- Material: Steel
- Plating: Trivalent zinc chromate

Dust Cover Material: Polycarbonate

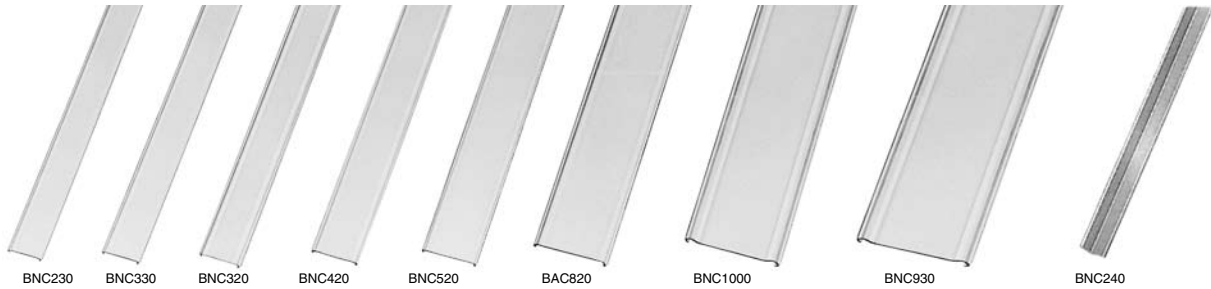

Length	Width (mm)	Part No.	Ordering No.	Terminal Blocks (□: No. of Poles)	Weight (Approx.)	Package Quantity
1m	39.6	BNC230	BNC230PN10	BN10W, BNH10W, BN15MW, BNH15MW, BN15LW, BNH15LW, BN30W, BNH30W, BN15MWT, BNH15MWT, BN15LWT, BNH15LWT	56g	10
	43	BNC330	BNC330PN10	BN40W, BNH40W	57g	10
	49.6	BNC320	BNC320PN10	BN50W, BNH50W	64g	10
	54.6	BNC420	BNC420PN10	BN75W	72g	10
	65	BNC520	BNC520PN10	BN150W, BN150NW, BNT20, BN100W	96g	10
	82	BAC820	BAC820PN10	BN200BW□(K), BN200NW□(K)	204g	10
	96	BNC910	BNC910PN10	BN300BW□(K), BN300NW□(K)	222g	10
	110	BNC1000	BNC1000PN10	BN400BW□(K), BN400NW□(K)	256g	10
	145	BNC930	BNC930PN10	BN500BW□(K), BN500NW□(K), BN600NW□(K)	310g	10

Dust Covers for Double Deck Terminal Blocks

Length	Part No.	Ordering No.	Terminal Block	Weight (Approx.)	Package Quantity
1m	Upper Deck BNC230	BNC230PN10	BND15W, BNDH15W, BND15LW, BNDH15LW, BND15WT, BNDH15WT	56g	10
	Lower Deck BNC240	BNC240PN10		15g	10

BN-W / BNH-W Series Terminal Blocks

Accessories (Marking Strips / Marking Strip Fastener / Slide Marking Strip)

Marking Strips, Marking Strip Fastener

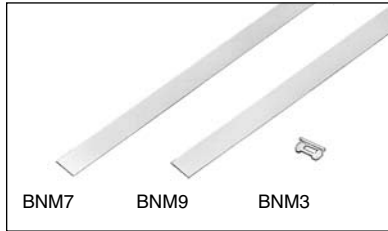

Item	Part No.	Ordering No.	Weight (approx.)	Package Quantity	Specification
Marking Strip	BNM7	BNM7PN10	7.2g	10	PVC (glossy surface) 1000 mm × 9.5 mm × 0.5 mm
	BNM9	BNM9PN10	6.4g	10	Fiber glass (matte surface) 1000 mm × 9.5 mm × 0.5 mm
	BNM725	BNM725	—	1	PVC (matte surface) 25 m × 9.5 mm × 0.5 mm
Marking Strip Fastener	BNM3	BNM3PN50	0.1g	50	

• To install the marking strip fastener

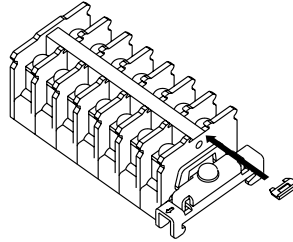
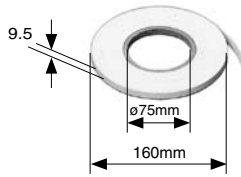

Sliding Marking Strip (BN10W to BN30W)

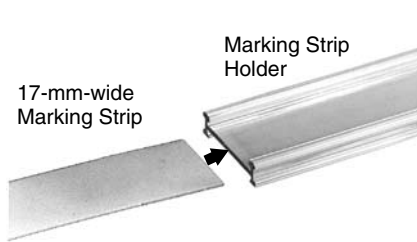

17-mm-wide marking strip
• Both top and bottom sides of the marking strip holder can be used.

End plate (Thickness 5 mm)
BNES15W
BNES30W



Item	Part No.	Ordering No.	Terminal Blocks	Specification	Package Quantity
① End Plate	BNES15W	BNES15WPN10	BN10W to BN15LWT	For sliding marking strip	10
	BNES30W	BNES30WPN10	BN30W	For sliding marking strip	10
② Marking Strip	BNM5	BNM5PN10	BN10W to BN15LWT BN30W	PVC (Note)	10
③ Marking Strip Holder	BNMH1	BNMH1PN10		1m	10
④ Dust Cover	BNCS230	BNCS230PN10		1m	10

Note: Length 1000 mm × Width 9.5 mm × Thickness 0.5 mm

Installing the Sliding Marking Strip

1. Insert the marking strip into the groove of the top of the marking strip holder.

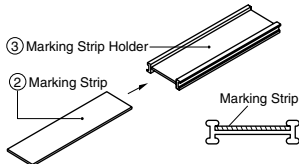

3. Insert the marking strip holder into the recess of the end plate.

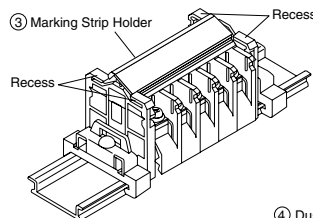

2. Installing the end plate
Attach the end plates to the terminal blocks and secure with end clips.

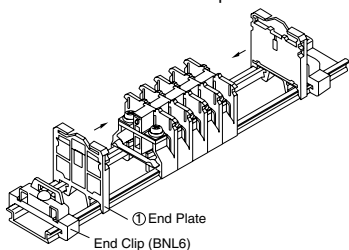

4. Press the dust cover to fit onto the bottom groove of the end plate.

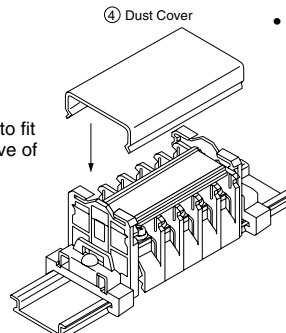

Movement

• Sliding movement of the marking strip holder

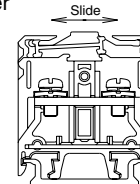

When sliding the marking strip holder, slide by holding both edges of the holder.

• To lock the marking strip holder

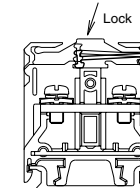

To lock the marking strip holder, lock by holding both edges of the holder.

BN-W / BNH-W Series Terminal Blocks

Accessories (Removal Tool)

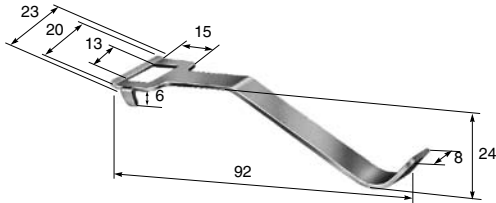

A tool for removing terminal blocks from the DIN rail.

Part No.	Weight (Approx.)	Package Quantity
BND2	8.6g	1

- Material: Steel
- Plating: Zinc

Accessories for BND Double-Deck Terminal Blocks

Surface Mounting Clip

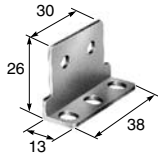

Part No.	Ordering No.	Applicable Terminal Block	Weight (Approx.)	Package Quantity
BNDL2	BNDL2PN10	BND15W, BNDH15W BND15WT, BNDH15WT BND15LW, BNDH15LW	14.3g	10

- Material: Steel
- Plating: Zinc

Connecting Rods



Part No.	Ordering No.	Applicable Terminal Block	Weight (Approx.)	Dimensions (mm)	Package Quantity
BNR1	BNR1PN10	BND15W, BNDH15W BND15WT, BNDH15WT	21g	265 mm (M4×0.7)	10
BNR2	BNR2PN10	BND15LW, BNDH15LW	43g	500 mm (M4×0.7)	10

- Material: Steel
- Plating: Zinc

Connecting Nuts

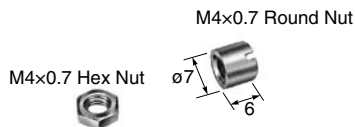

Part No.	Ordering No.	Applicable Terminal Block	Weight (Approx.)	Package Quantity
BNN1	BNN1PN1H	BND15W, BNDH15W BND15WT, BNDH15WT BND15LW, BNDH15LW	14g	100 (pairs of both nuts)

- Material: Steel
- Plating: Zinc

BN-W / BNH-W Series Terminal Blocks

Calculating Rail Lengths and Mounting Centers

- BNCA, BNCP, BAA, BAP, and BNJA Rails

$$L_1 = 12.5 \times N$$

$$L_2 = L_1 - 25$$

Note: This formula is for calculating the maximum rail length including tolerance. Depending on the combination of terminal blocks, the required rail length may be shorter than the calculated value, particularly when many terminal blocks are combined.

N: Rounded up numerical number from the calculated value of M.
(Example: N for 19.1 is 20)

$$M = \frac{(A + 0.1)n + B + C}{12.5}$$

- A: Thickness of each terminal block
- B: Thickness of end plate
- C: Thickness of end clip when using 2 pieces of:
 - BNL6 = 56.0 mm
 - BNL7 = 62.5 mm
 - BNL8 = 67.0 mm
- n: The number of terminal blocks

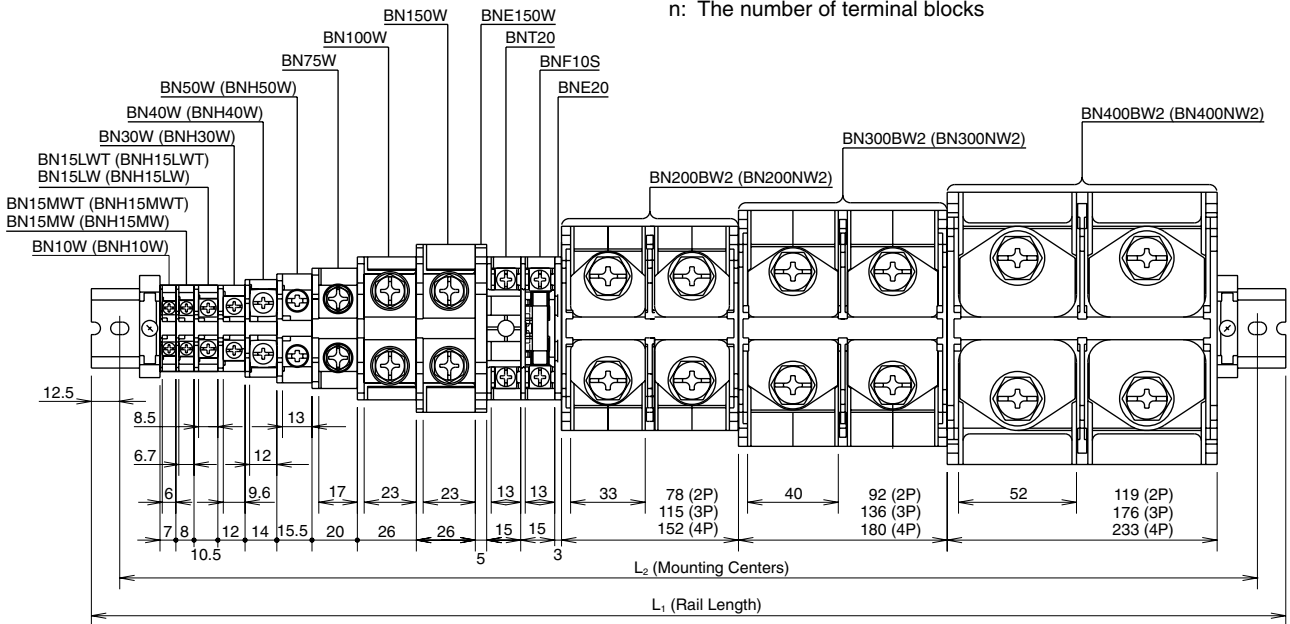

Rail Length (Double-Deck)

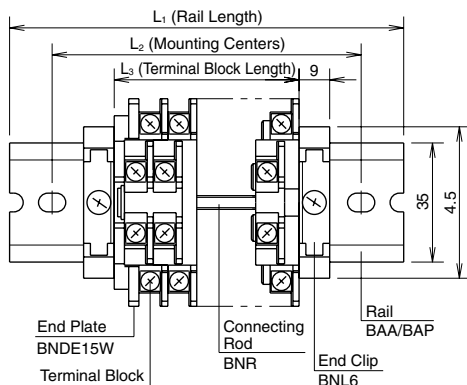

Mounting Centers (Double-Deck)

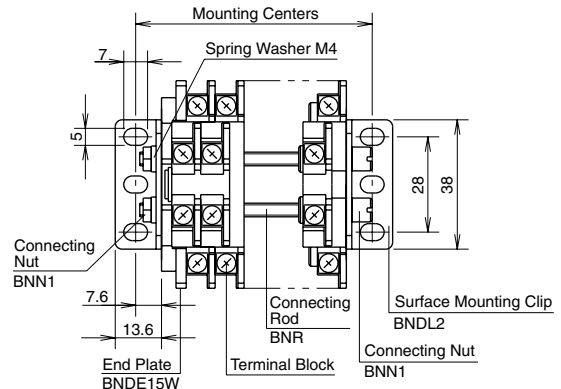

Calculating the length (mm)

Part No.	BND15W BNDH15W BND15WT	BND15LW BNDH15LW
L1 (*1)	12.5 × N	
L2 (*2)	L ₁ - 25	
L3 (*1, *2)	8 × n + 9	10.5 × n + 10.3
Connecting Rod Length (*1, *2)	8 × n + 8.7	10.5 × n + 10

N: Rounded up numerical number from the calculated value of M.
(Example: N for 19.1 is 20)

For BND15W, BNDH15W, BND15WT For BND15LW, BNDH15LW

$$M = \frac{(8 \times n + 9 + 62.5)}{12.5}$$

$$M = \frac{10.5 \times n + 10.3 + 62.5}{12.5}$$

Calculating the length (mm)

Part No.	BND15W BNDH15W BND15WT	BND15LW BNDH15LW
Mounting Centers (*1, *2)	8 × n + 24.2	10.5 × n + 25.5
Connecting Rod Length (*1, *2)	8 × n + 20.2	10.5 × n + 21.5

n: The number of terminal blocks

*1: This formula is for calculating the maximum rail length including tolerance. Depending on the combination of terminal blocks, the required rail length may be shorter than the calculated value, particularly when many terminal blocks are combined.

*2: The length will be 1.5 mm longer when end plates BNDE15W2 and BNDE15LW2 are used.

BN-W / BNH-W Series Terminal Blocks

Instructions

How to Use Touch-Down Terminals



1. With the terminal screws in the up position, insert a ring crimping terminal.



2. Push down the head of the screw lightly to hold the crimping terminal.

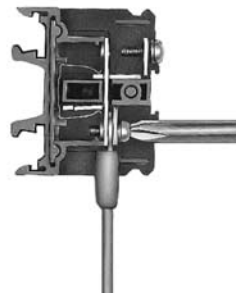

3. When the wiring is in position, tighten all the screws simultaneously.

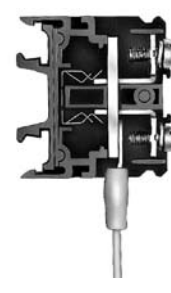

4. To remove the wiring, loosen the screw and lightly push up.

Installation and Removal on Rails

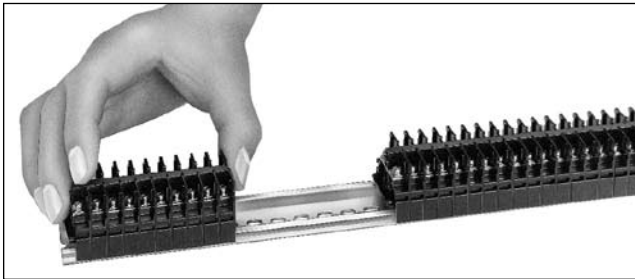

Additional Installation and Removal (on DIN Rail)

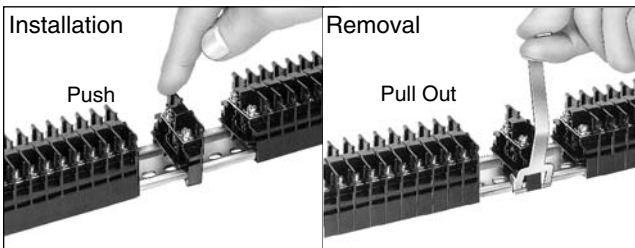

Notes: The following terminal blocks can be added or removed:
 BN10W, BNH10W, BN15MW, BNH15MW, BN15LW,
 BNH15LW, BN30W, BNH30W, BN15MWT, BNH15MWT,
 BN15LWT, BNH15LWT

Securing the Ends of the Marking Strip

The ends of the marking strip can be secured with a marking strip fastener (or end plate).

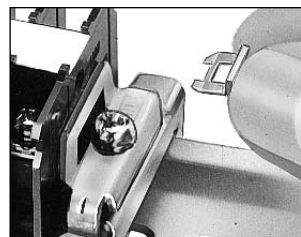

To Secure the Marking Strip

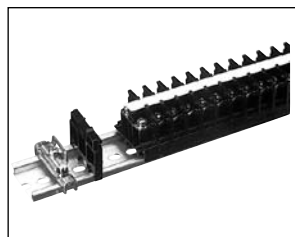

Installing End Plate

For double-deck, use an end plate to secure marking strips (BNDE15W2, BNDE15LW2).

Installation of Double-Deck Terminal Blocks (BND)

Rail Mount (photo: when using BND15W, BNDH15W, BNDE15W2)

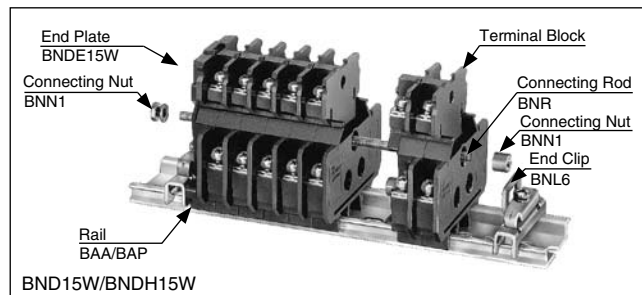

1. Install end plate. Then mount the terminal blocks onto the DIN rail.
2. Insert connecting rod (BNR) through each hole of the terminal blocks.
3. Secure the ends of the connecting rods with connecting nuts (BNN1).
4. To prevent side-to-side movement on the DIN rail, use the BNL6 end clips at both ends of the rail.

Surface Mount

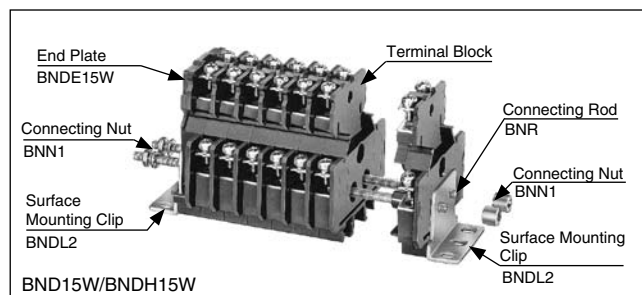

1. Assemble a row of terminal blocks with end plates on exposed ends.
2. Use BNDL2 mounting clips at both ends of a row.
3. With the two holes of the mounting clip (BNDL2) aligned with the terminal block holes, insert a connecting rod (BNR) through each hole.
4. Secure the ends of the connecting rods with the connecting nuts (BNN1).

Instructions

Dust Covers on the Lower Deck Terminal of Double-Deck Terminal Blocks

Installing Dust Covers on Lower Deck Terminals

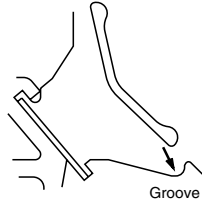
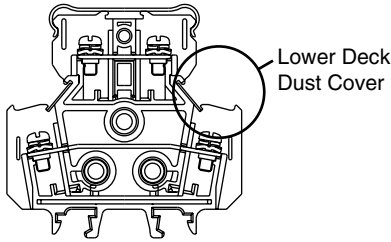

1. Press the lower end of the dust cover into the groove.

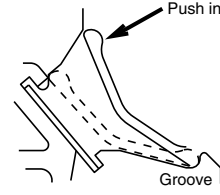

2. With the lower end of the dust cover pressed into the groove, push in the top end in the direction of the arrow.

Removing Dust Covers from Lower Deck Terminals

Turn the power off before removing the dust cover.

1. Hold the end of the dust cover which is extruding from the end plate.

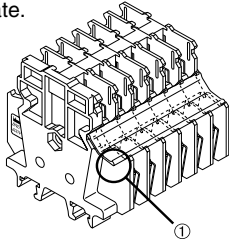

2. Lift up in the direction of the arrow.
3. If the dust cover cannot be removed all at once, place fingers between the terminal block and dust cover, and slowly remove the dust cover.

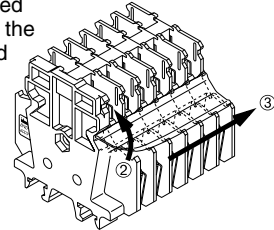

Length of Double-Deck Dust Covers

Upper-Deck Dust Cover
BNC230

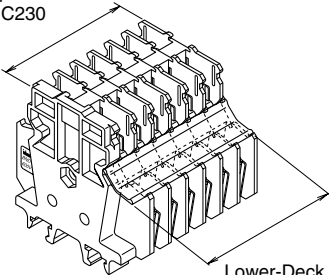

Lower-Deck Dust Cover
BNC240

Cut required length depending on the number of terminal blocks used. (Length in mm)

Terminal Block	Dust Cover	1-pole	2-pole	3-pole	4-pole	5-pole	6-pole	7-pole	8-pole	n-pole
BND(H)15W BND(H)15WT	Upper Deck	12	20	28	36	44	52	60	68	$8(n+1) - 4$
	Lower Deck	16	24	32	32	48	56	64	72	$8(n+1)$
BND(H)15LW	Upper Deck	16	26.5	37	47.5	58	68.5	79	89.5	$10.5(n+1) - 5$
	Lower Deck	21	31.5	42	52.5	63	73.5	84	94.5	$10.5(n+1)$

Securing Marking Strip with Marking Strip Fasteners for Double-Deck Terminal Blocks

Because marking strips can be secured without using marking strip fasteners, installation time can be shortened. Also, marking strips can be inserted and removed after installation.

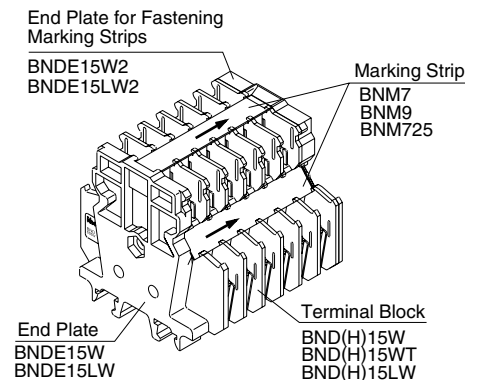
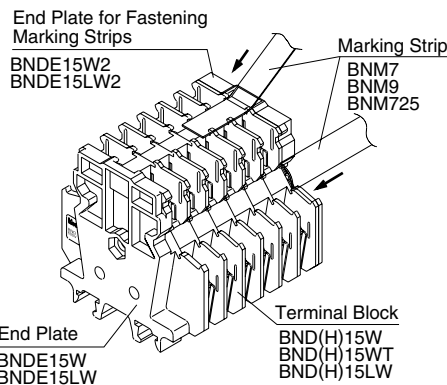

Notes on Wiring

Crimping Terminals

When using crimping terminals, be sure to use insulated terminals to prevent electric shocks.

Without Crimping Terminals

- Insert the wire until the insulation comes into contact with the terminal metal part.
- Strip the insulation so that the wire is longer than the width of the wire clamp.
- When connecting two wires, use wires of the same size.

